

# FLUIDRAIN® COMBO QUICK SET

Electronic timer controlled condensate drain

## PRODUCT FEATURES

The FLUIDRAIN®COMBO QUICK SET removes condensate from compressed air systems using a direct acting solenoid valve in combination with an electronic timer.

The integrated ball valve and strainer protect the valve by filtering out large dirt and rust particles.

Simply select the compressor capacity and pressure – and GO!

The integrated ball valve can be closed enabling safe and easy service and maintenance work to be carried out.



## COMMERCIAL BENEFITS

- Suitable for all compressed air systems up to 16 bar.
- Prominent front facing private labeling area possibilities.
- 12 – 380 VAC/DC voltage options are available.
- Successful draining of all types of condensate (also heavily emulsified condensate).



## TECHNICAL ADVANTAGES

- Simply select the compressor capacity and pressure – and GO!
- Visual display of operating status.
- Application environment up to IP65 (NEMA 4)
- Newly designed easy-grip adjusting knobs.
- Integrated ball valve strainer.
- Can not be air-locked.
- Direct acting valve assembly, ensuring consistent discharge operation.

## WARNING

Failure to ensure that the drain has IP65 enclosure rating can have catastrophic results when installing a drain outdoors. Compressed air systems can become contaminated and production schedules can get seriously disrupted – just because a simple duty has been neglected.

# FLUIDRAIN® COMBO QUICK SET

Electronic timer controlled condensate drain

## DIMENSIONS MM

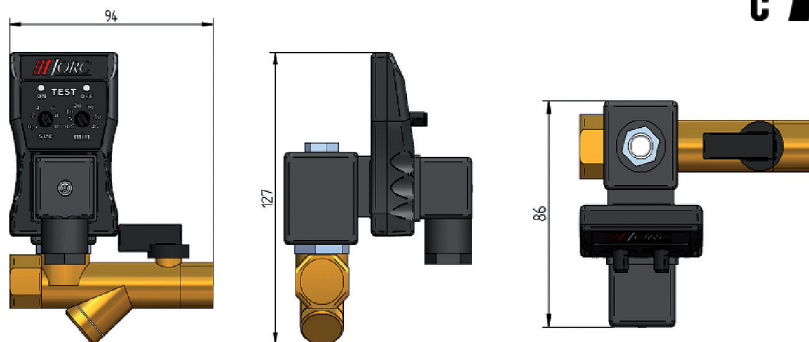

Combo valve with ball valve and strainer

## SPECIFICATIONS

### TIMER

Interval time	Adjustable according to comp. capacity
Discharge time	Adjustable according to pressure
Supply voltage options	12 - 380 VAC/DC, 50/60 Hz
Current consumption	4mA maximum
Operating temperature	-40° C to +60° C
Environmental protection	IP 65, NEMA 4 when installed
Housing material	ABS plastic FR grade
Connection	DIN 43650A ISO 440/6952
Indicators	1 LED (yellow) indicating ON 1 LED (yellow) indicating OFF



Dual inlet: 1/2" / 1/4"

### VALVE

Type	2/2 way direct acting
In/out ports	1/2" (dual inlet port 1/2" & 1/4") BSP or NPT
Max. pressure	16 bar g
Min/Max temperature	2° C/55° C ambient
Media temp.	Max. 90° C
Valve body	Forged brass, orifice 4.0 mm
Supply voltage options	12 - 380 VAC/DC, 50/60 Hz (100% ED)
Coil Insulation Grade	H-grade
Valve seal	FPM (Viton)
Environmental Protection	IP 65

Timer units available in different colours



See coil for correct voltage      Voltage tolerance +/- 10%

**JORC IS ISO 9001:2008 CERTIFIED**

Information provided herewith is believed to be accurate and reliable. However, no responsibility is assumed for its use or for any infringement of patents or rights of others, which may result from its use. In addition, JORC reserves the right to revise information without notice and without incurring any obligation.

<b>JORC Industrial BV</b>	Tel	+31 45 524 24 27
Pretoriastraat 28	Fax	+31 45 524 19 79
NL-6413 NN Heerlen	E-mail	info@jorc.nl
The Netherlands	http://	www.jorc.eu